

PORTAVALIGIE LATERALE SPECIFICO - SPECIFIC TUBULAR SIDE-CASE HOLDER  
 PORTE-VAISES LATÉRAUX SPÉCIFIQUE - SPEZIFISCHES STAHLROHR-SEITENTRÄGER  
 PORTA MALETAS LATERALES ESPECÍFICO

# BMW K1300S 2009

ISTRUZIONI DI MONTAGGIO - MOUNTING INSTRUCTIONS  
 INSTRUCTIONS DE MONTAGE - BAUANLEITUNG - INSTRUCCIONES DE MONTAJE

①  
  
**SUPPORTO**  
 SUPPORT  
 SUPPORT  
 HALTERUNG  
 SOPORTE  
**Q.TY n.2(Dx-Sx)**

②  
  
**SUPPORTO**  
 SUPPORT  
 SUPPORT  
 HALTERUNG  
 SOPORTE  
**Q.TY n.2(Dx-Sx)**

③  
  
**SUPPORTO**  
 SUPPORT  
 SUPPORT  
 HALTERUNG  
 SOPORTE  
**Q.TY n.2(Dx-Sx)**

④  
  
**PONTE POSTERIORE**  
 REAR BRIDGE  
 PONT POSTÉRIEURE  
 VERBINDUNGSROHR  
 PUENTE TRASERO  
**Q.TY n.1**

⑤  
  
**SUPPORTO**  
 SUPPORT  
 SUPPORT  
 HALTERUNG  
 SOPORTE  
**Q.TY n.1**

⑥  
  
**VITE TBEI M8x20mm**  
 SCREW  
 VIS  
 SCHRAUBE  
 TORNILLO  
**Q.TY n.2**

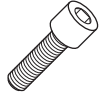
⑦  
  
**VITE TCEI M8x45mm**  
 SCREW  
 VIS  
 SCHRAUBE  
 TORNILLO  
**Q.TY n.4**

⑧  
  
**VITE TEF M6x20mm**  
 SCREW  
 VIS  
 SCHRAUBE  
 TORNILLO  
**Q.TY n.2**

⑨  
  
**RONDELLA Ø8x14mm**  
 WASHER Ø8x14mm  
 RONDELLE Ø8x14mm  
 SCHEIBE Ø8x14mm  
 ARANDELA Ø8x14mm  
**Q.TY n.6**

⑩  
  
**DISTANZIALE Ø14x15mm**  
 Foro Ø8,5mm, V750  
 SPACER  
 ENTRETÔISE  
 DISTANZSTÜCK  
 DISTANCIADOR  
**Q.TY n.2**

⑪  
  
**DISTANZIALE Ø16x4mm**  
 Foro Ø8,5mm, V004  
 SPACER  
 ENTRETÔISE  
 DISTANZSTÜCK  
 DISTANCIADOR  
**Q.TY n.2**

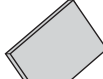
⑫  
  
**MOUSSE**  
 30 X 16 mm  
 MOUSSE/GUMMI  
 MOUSSE  
 MOUSSE  
**Q.TY n.2**

⑬  
**COMPONENTI ORIGINALI**  
 ORIGINAL PARTS  
 PARTES ORIGINALES  
 ORIGINAL BAUTEILE  
 COMPONENTES ORIGINALES  
**Q.TY n.-**

⑭  
  
**CHIAVE PER VITI A TESTA SPECIALE**  
 SPECIAL KEY  
 CLÉ SPECIALE  
 SPEZIALSCHLÜSSEL ZUR DEMONTAGE DES TRÄGERS  
 LLAVE PARA TORNILLOS CON CABEZA ESPECIAL  
**Q.TY n.1**

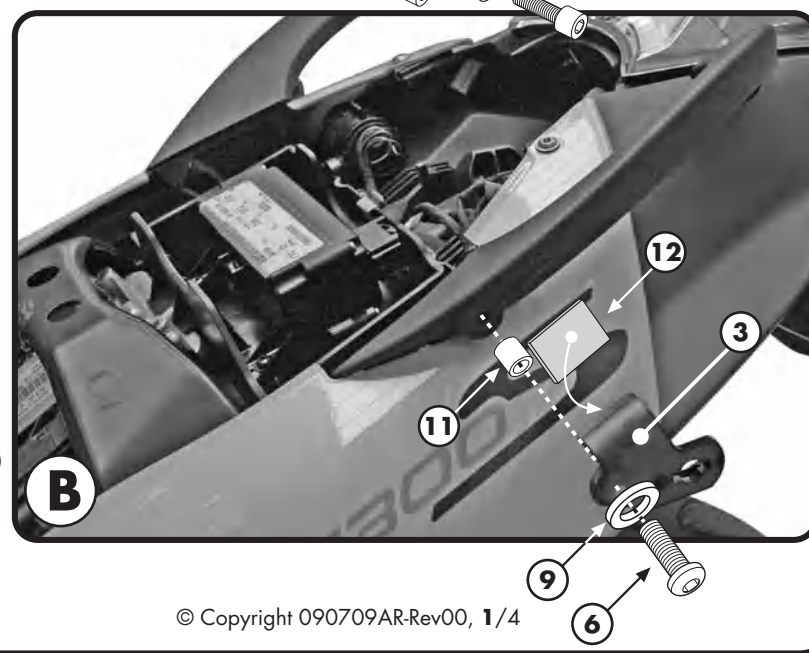
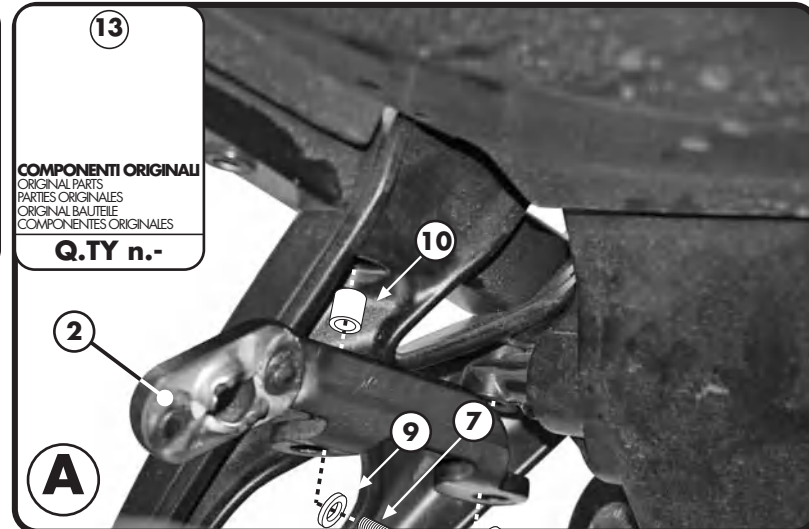
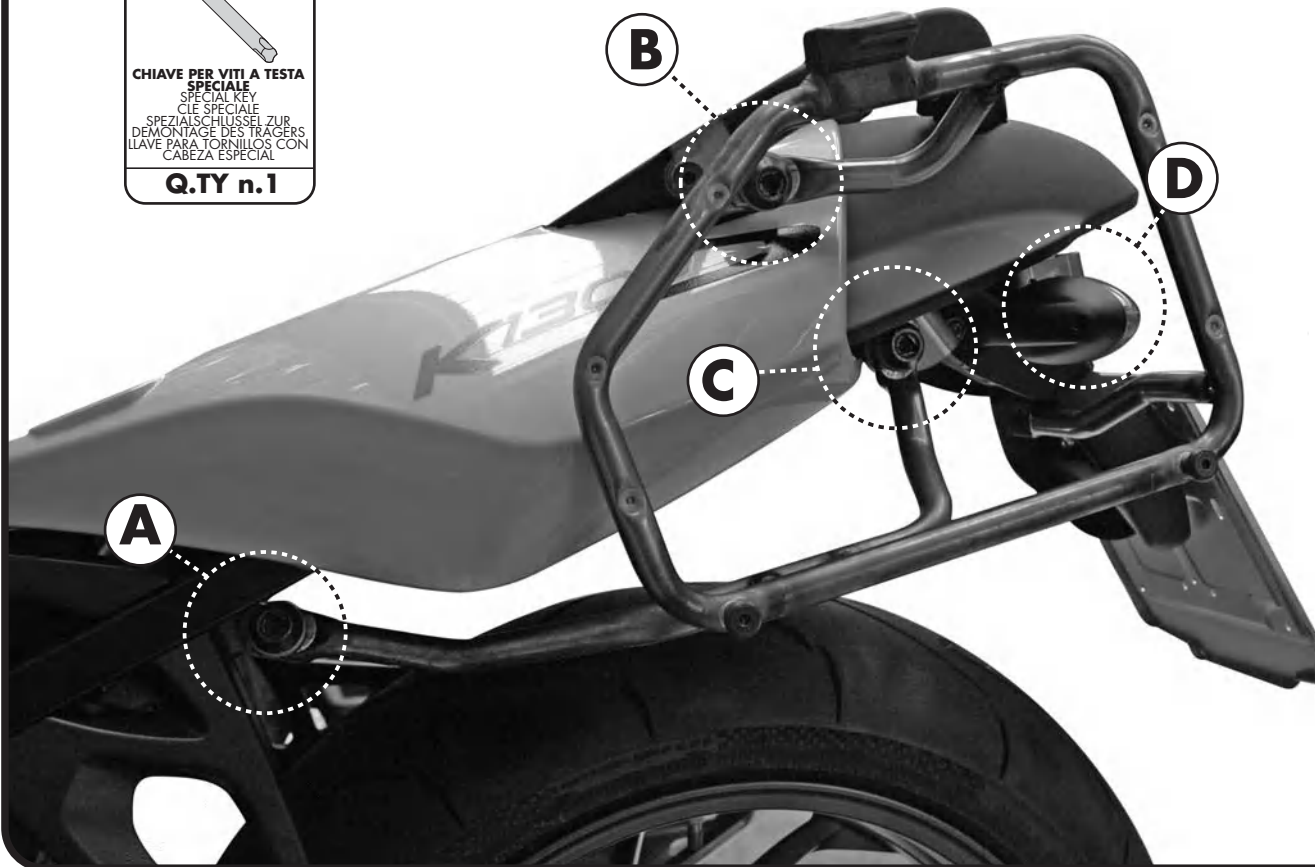

PORTAVALIGIE LATERALE SPECIFICO - SPECIFIC TUBULAR SIDE-CASE HOLDER  
PORTE-VAISES LATÉRAUX SPÉCIFIQUE - SPEZIFISCHES STAHLROHR-SEITENTRÄGER  
PORTA MALETAS LATERALES ESPECÍFICO

# BMW K1300S 2009

ISTRUZIONI DI MONTAGGIO - MOUNTING INSTRUCTIONS  
INSTRUCTIONS DE MONTAGE - BAUANLEITUNG - INSTRUCCIONES DE MONTAJE

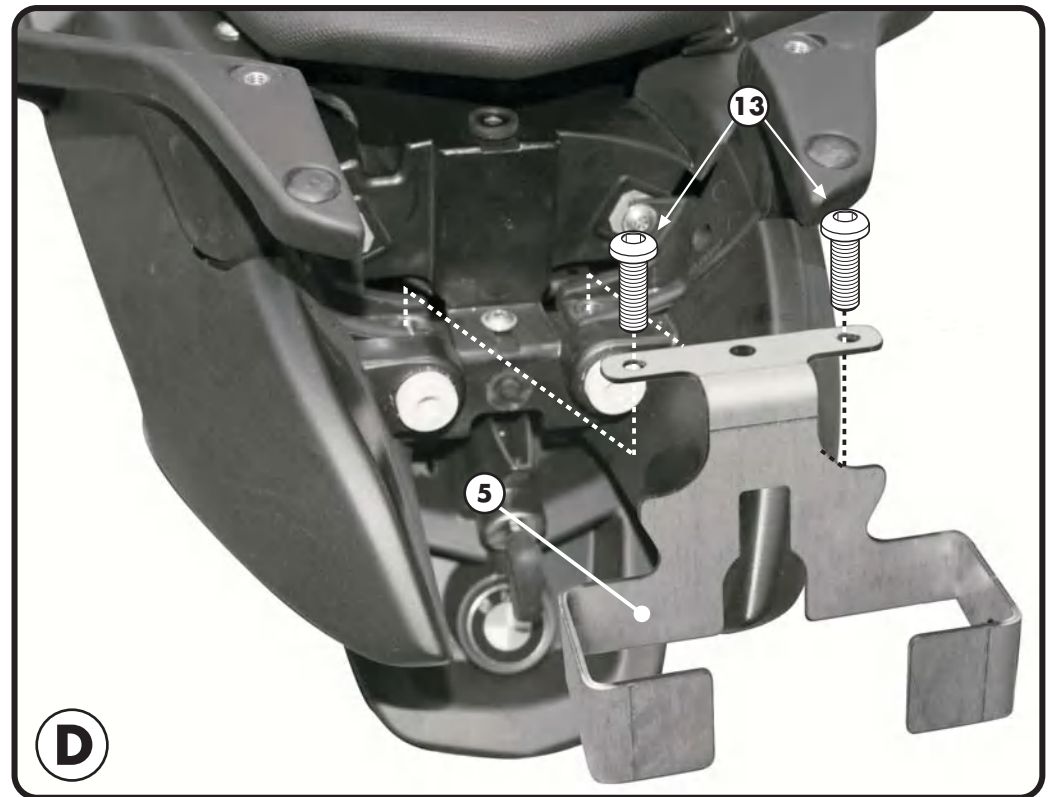
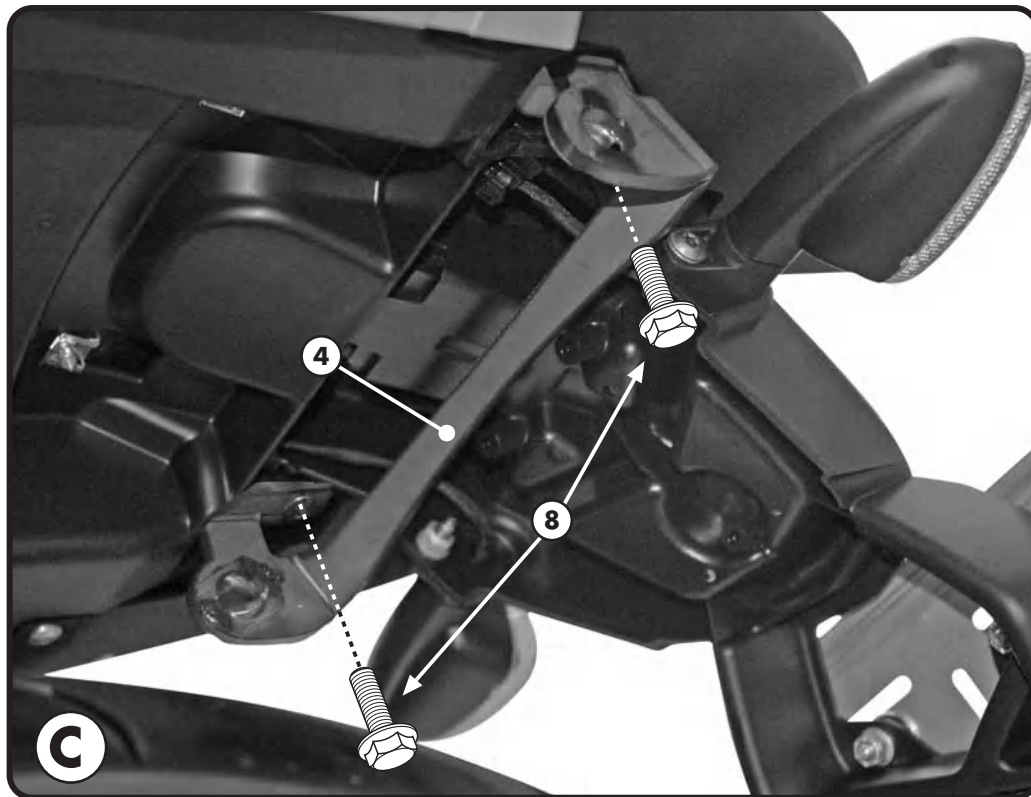

## MONTAGGIO / SMONTAGGIO PORTAVALIGE LATERALE VERSIONE PLXR "RAPID"



**I**

1. INSERIRE L'ATTREZZO NELLA TESTA DELLA VITE SPECIALE;
2. RUOTARE DI 1/4 DI GIRO IN SENSO ORARIO FINO A CHÉ LA ROTAZIONE NON TERMINA E SI AVVERTE LO SCATTO;
3. PER SMONTARE PROCEDERE IN SENSNO INVERSO.

**GB**

1. INSERT THE SPECIAL KEY INTO THE HEAD OF THE SCREW;
2. TURN THE KEY ¼ TURN CLOCKWISE UNTIL ROTATION STOPS AND THE SIDE CASE HOLDER IS FASTENED SECURELY TO THE FITMENT POINT;
3. IN ORDER TO DISASSEMBLE THE BRACKETRY PERFORM THE OPERATION IN REVERSE.

**F**

1. INSERER LA CLE SPECIALE DANS LA TETE DE LA VIS;
2. VISSER D'1/4 DE TOUR DANS LE SENS HORAIRE JUSQU'AU BLOCAGE DE LA VIS POUR MONTER EN TOUTE SECURITE LE SUPPORT A SON POINT DE FIXATION;
3. POUR LE DEMONTAGE, PROCEDER EN SENSE INVERSE.

**D**

1. STECKEN SIE DAS WERKZEUG IN DEN KOPF DER SPEZIFISCHEN SCHRAUBE;
2. DREHEN SIE DIE SCHRAUBE 1 / 4 UMDREHUNG IM UHRZEIGERSINN BIS SIE BEMERKEN, DASS DIE SCHRAUBE IM BEFESTIGUNGSPUNKT EINGEKLEMMT IST;
3. FÜR DIE DEMONTAGE FOLGEN SIE DEN HINWEISE UMGEKEHRT.

**ES**

1. INSERTAR LA LLAVE ESPECIAL EN LA CABEZA DEL TORNILLO
2. DAR ¼ DE VUELTA EN EL SENTIDO HORARIO HASTA QUE LLEGUE AL TOPE Y SE VEA EL TORNILLO;
3. PARA DESMONTARLO PROCEDER EN LA DIRECCIÓN CONTRARIA;

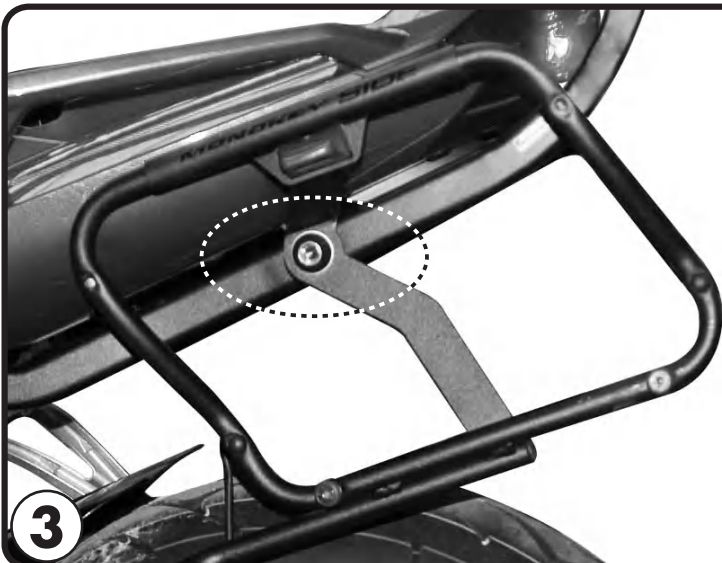

### VITE NASCOSTA

LA VITE NASCOSTA IMPEDISCE LO SMONTAGGIO DEL PLXR QUANDO LA VALIGIA E' MONTATA

### HIDDEN SCREW

THE HIDDEN SCREW DOES NOT ALLOW THE PLXR TO BE REMOVED WHEN THE CASE IS MOUNTED

### VIS CACHEE

LA VIS CACHEE EMPECHE LE DEMONTAGE DU PLXR QUAND LA VALISE EST MONTEE.

### DIE SCHRAUBE IST VERSTECKT

DIE VERSTECKTE SCHRAUBE ERMÖGLICHT KEINE DEMONTAGE DES PLXR WENN DER KOFFER MONTIERT IST.

### TORNILLO OCULTO

EL TORNILLO OCULTO IMPIDE PODER DESMONTAR EL PLXR CUANDO LA MALETA ESTÀ MONTADA.

PORTAVALIGIE LATERALE SPECIFICO - SPECIFIC TUBULAR SIDE-CASE HOLDER  
 PORTE-VALISES LATÉRAUX SPÉCIFIQUE - SPEZIFISCHES STAHLROHR-SEITENTRAEGER  
 PORTA MALETAS LATERALES ESPECÍFICO

# BMW K1300S 2009

ISTRUZIONI DI MONTAGGIO - MOUNTING INSTRUCTIONS  
 INSTRUCTIONS DE MONTAGE - BAUANLEITUNG - INSTRUCCIONES DE MONTAJE

## I ISTRUZIONI DI MONTAGGIO

1. SMONTARE LE FRECCHE E MONTARLE SUL PORTAFRECCHE N°5;
2. MONTARE I SUPPORTI N°2 AI SUPPORTI DELLE PEDALINE PASSEGGERO COME INDICATO IN FIGURA A;
3. FISSARE I SUPPORTI N°3 ALLE MANIGLIE ORIGINALI (FIGURA B) ED IL PONTE N°4 SOTTO IL CODONE DELLA MOTO COME MOSTRA LA FIGURA C;
4. TERMINARE IL MONTAGGIO ASSICURANDOSI CHE TUTTE LE VITI SIANO SERRATE BENE (VITI M6=9.6NM, VITI M8=23NM).

## GB MOUNTING INSTRUCTIONS

1. DISASSEMBLE THE REAR LIGHTS AND MOUNT THEM ON THE REAR LIGHT HOLDERS N°5;
2. SET THE SUPPORTS N°2 TO THE PASSENGER FOOTREST'S AS YOU CAN SEE FROM PICTURE A;
3. FIX THE SUPPORTS N°3 TO THE ORIGINAL HANDLES (PICTURE B) AND THE BRIDGE N°4 UNDER THE BIG TAIL OF THE MOTORCYCLE AS YOU CAN SEE FROM PICTURE C;
4. CHECK THAT ALL THE SCREWS ARE WELL TIGHTENED (SCREWS M6=9,6Nm - SCREWS M8=23Nm).

## F INSTRUCTIONS DE MONTAGE

1. DEMONTER LES CLIGNOTANTS D'ORIGINE ET LES MONTER SUR LES PORTE-CLIGNOTANTS N°5;
2. MONTER LES SUPPORTS N°2 AUX PLATINES DES REPOSE-PIEDS PASSAGER COMME INDIQUE EN PHOTO A;
3. FIXER LES SUPPORTS N°3 AUX POIGNEES (PHOTO B) ET LE PONT N°4 SOUS L'ARRIERE DE LA MOTO COMME ILLUSTRE EN PHOTO C;
4. TERMINER LE MONTAGE EN CONTROLANT LE BON SERRAGE DE TOUTES LES VIS (VIS M6=9,6Nm - VIS M8=23Nm).

## D BAUANLEITUNG

1. DEMONTIEREN SIE DIE BLINKER UND MONTIEREN SIE DIESE AUF DEM BLINKERTRÄGER N°5;
2. MONTIEREN SIE DIE HALTERUNGEN N°2 AN DEN FUßRÄSTERN WIE IM BILD A GEZEIGT;
3. BEFESTIGEN SIE DIE HALTERUNGEN N°3 AN DEN ORIGINAL HANDGRIFFEN (BILD B) UND DIE BRÜCKE N°4 UNTER DEM HECK DES MOTORRADS WIE IM BILD C GEZEIGT;
4. ZULETZT ÜBERPRÜFEN SIE DASS ALLE SCHRAUBEN (SCHRAUBEN M6=9.6NM, SCHRAUBEN M8=23NM) FESTGEZOGEN WURDEN.

## ES INSTRUCCIONES DE MONTAJE

1. DESMONTAR LOS INTERMITENTES Y MONTARLOS EN EL SOPORTE N. 5;
2. MONTAR LOS SOPORTES N2 A LOS SOPORTES DE LOS ESTRIBOS DEL PASAJERO COME SE INDICA EN LA FOTO A;
3. FIJAR LOS SOPORTES N3 A LOS ASIDEROS ORIGINALES (FOFOB) Y LA REFERENCIA N4 BAJO EL COLIN DE LA MOTO COMO SE MUESTRA EN LA FOTO C;
4. TERMINAR EL MONTAJE VERIFICANDO QUE TODOS LOS TORNILLOS ESTÉN BIEN APRETADOS ((TORNILLOS M6=9,6NM - TORNILLOS M8=23NM).