

265FZ-KZ265

MONORACK SPECIFICO - SPECIFIC MONORACK
MONORACK SPECIFIQUE - SPEZIFISCHES MONORACK - MONORACK ESPECÍFICO

HONDA DN-01 2008

ISTRUZIONI DI MONTAGGIO - MOUNTING INSTRUCTIONS
INSTRUCTIONS DE MONTAGE - BAUANLEITUNG - INSTRUCCIONES DE MONTAJE

1



SUPPORTO
SUPPORT
SUPPORT
HALTERUNG
SOPORTE

Q.TY n.2(Dx-Sx)

2



SUPPORTO
SUPPORT
SUPPORT
HALTERUNG
SOPORTE

Q.TY n.2(Dx-Sx)

3



CAVALLOTTO M6
U-BOLT
CAVALIER
BUEGELSCHRAUBE
ABARCÓN

Q.TY n.2

4



SUPPORTO
SUPPORT
SUPPORT
HALTERUNG
SOPORTE

Q.TY n.2

5

PARTICOLARI INCLUSI NEL KIT VITERIA DELLA PIASTRA
COMPONENTS INCLUDED IN THE FITTING KIT OF THE PLATE
PIÈCES INCLUES DANS LE KIT DE VIS DE LA PLATINE
DIE EINZELNEN TEILE SIND BEI MONTAGEKIT DER PLATTE ENTHALTEN
DESPIECES INCLUIDOS EN EL KIT DE ANCLAJES DE LA PARRILLA

Q.TY n.-

6

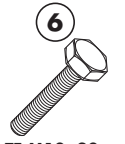

VITE TE M10x20mm
SCREW
VIS
SCHRAUBE
TORNILLO

Q.TY n.2

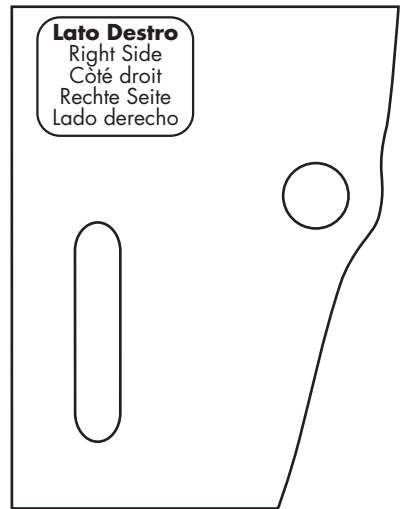
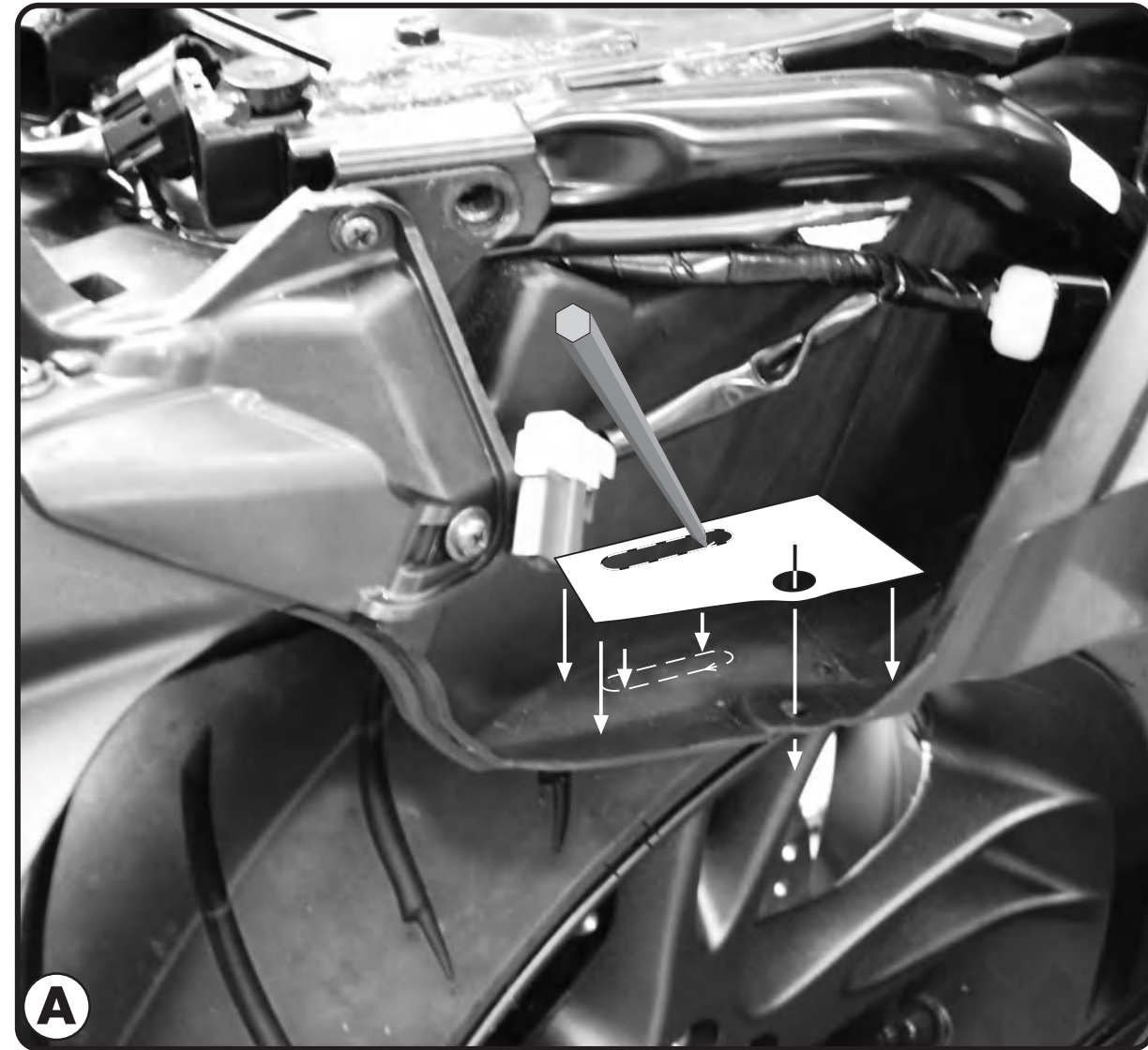
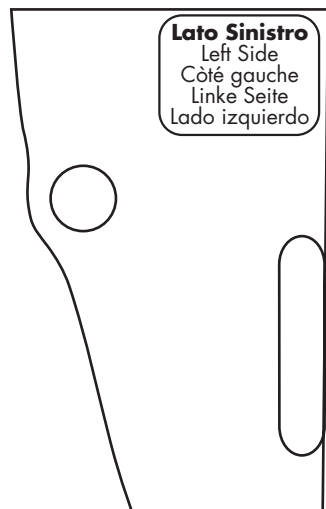

A

265FZ-KZ265

MONORACK SPECIFICO - SPECIFIC MONORACK
MONORACK SPECIFIQUE - SPEZIFISCHES MONORACK - MONORACK ESPECÍFICO

HONDA DN-01 2008

ISTRUZIONI DI MONTAGGIO - MOUNTING INSTRUCTIONS
INSTRUCTIONS DE MONTAGE - BAUANLEITUNG - INSTRUCCIONES DE MONTAJE

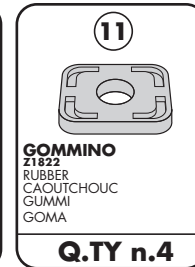
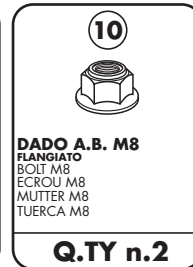
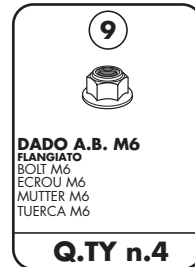
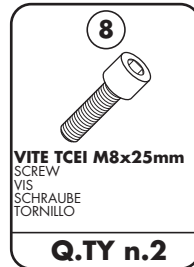
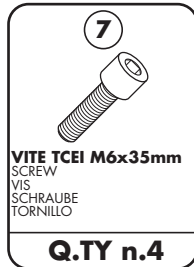

ATTENZIONE: PESO MASSIMO SOPPORTABILE 6Kg.

WARNING: MAX. LOADING 6Kg. (13lbs)

ATTENTION: CHARGE MAXIMALE 6Kg.

ACHTUNG: MAXIMALE BELASTUNG 6Kg.

¡ATENCIÓN!: CARGA MÁXIMA AUTORIZADA 6Kg.

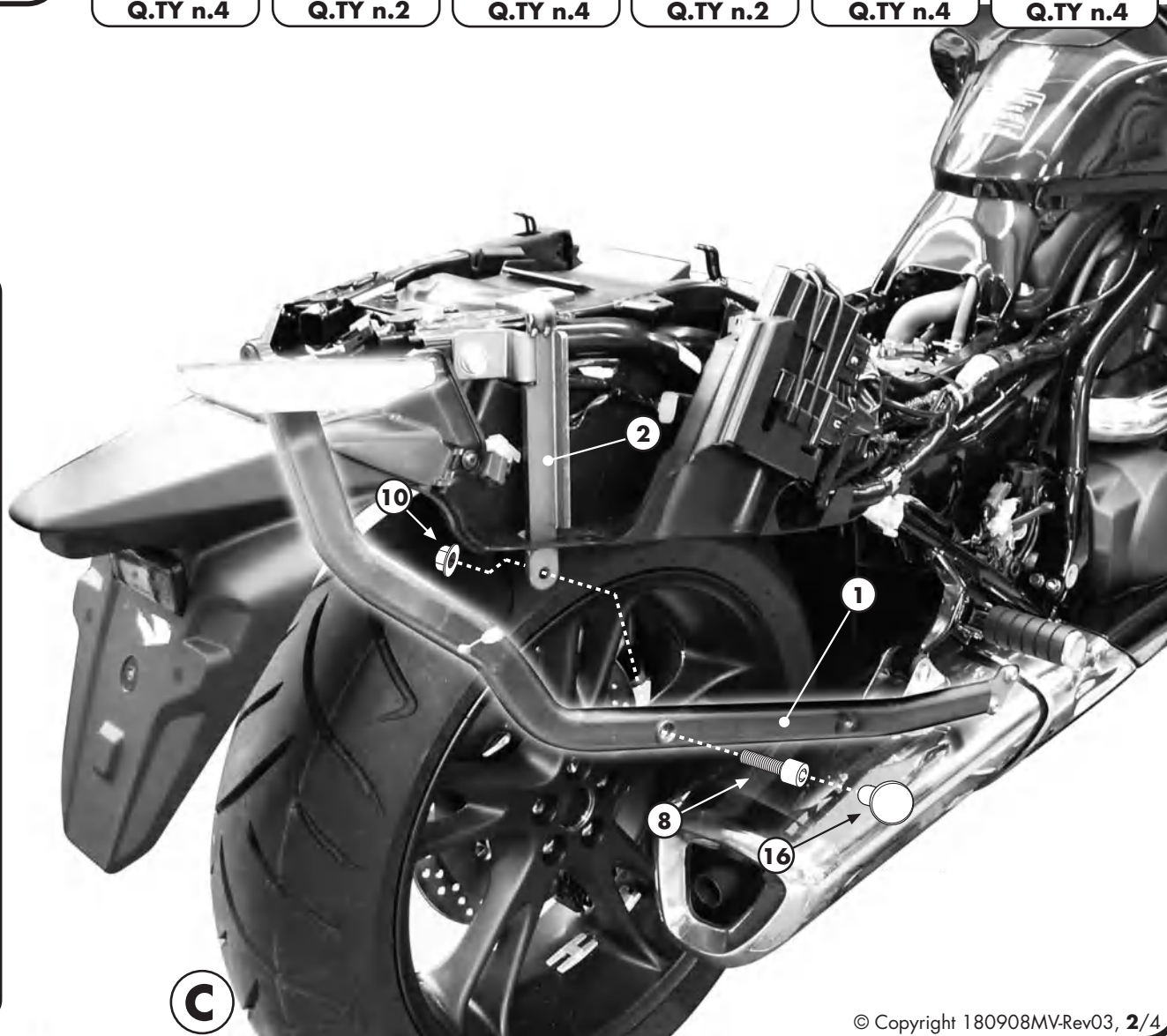
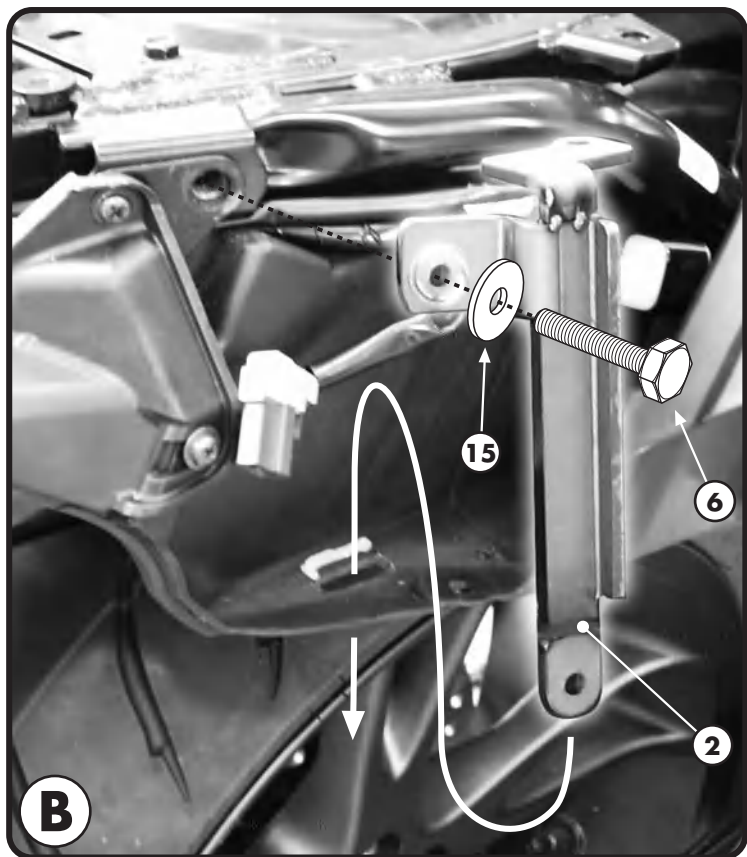

265FZ-KZ265

MONORACK SPECIFICO - SPECIFIC MONORACK
MONORACK SPECIFIQUE - SPEZIFISCHES MONORACK - MONORACK ESPECÍFICO

HONDA DN-01 2008

ISTRUZIONI DI MONTAGGIO - MOUNTING INSTRUCTIONS
INSTRUCTIONS DE MONTAGE - BAUANLEITUNG - INSTRUCCIONES DE MONTAJE

13

**DISTANZIALE Ø11x11mm
foro Ø6,5mm**
V687
SPACER
ENTRETOISE
DISTANZSTÜCK
DISTANCIADOR
Q.TY n. 4

14

RONDELLA Ø6x20mm
WASHER
RONDELLE
SCHEIBE
ARANDELA
Q.TY n.4

15
COMPONENTI ORIGINALI
ORIGINAL PARTS
PARTIES ORIGINALES
ORIGINAL BAUTEILE
COMPONENTES ORIGINALES
Q.TY n.-

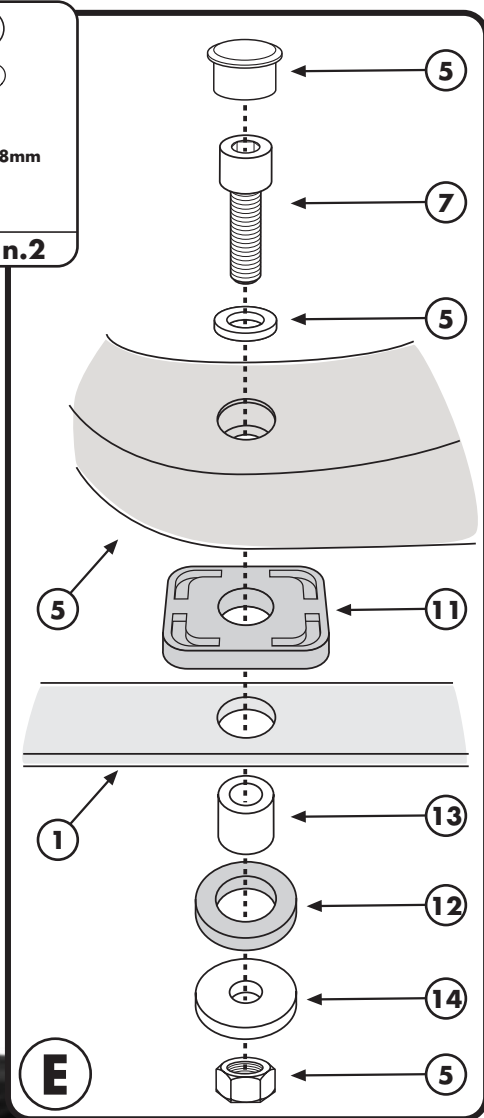
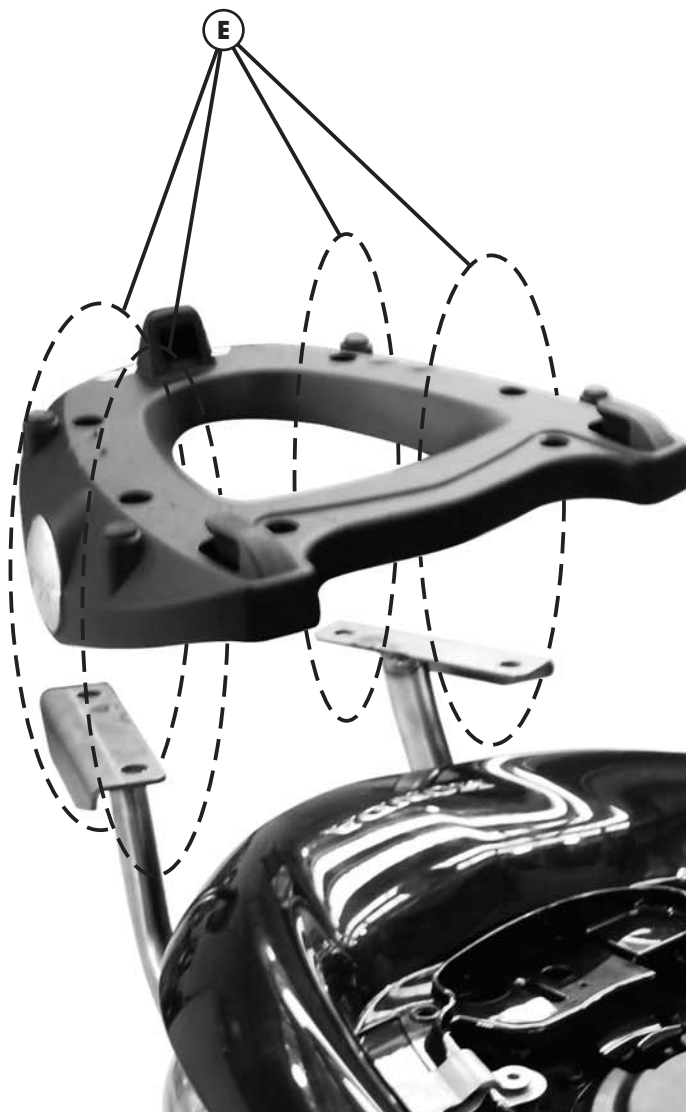
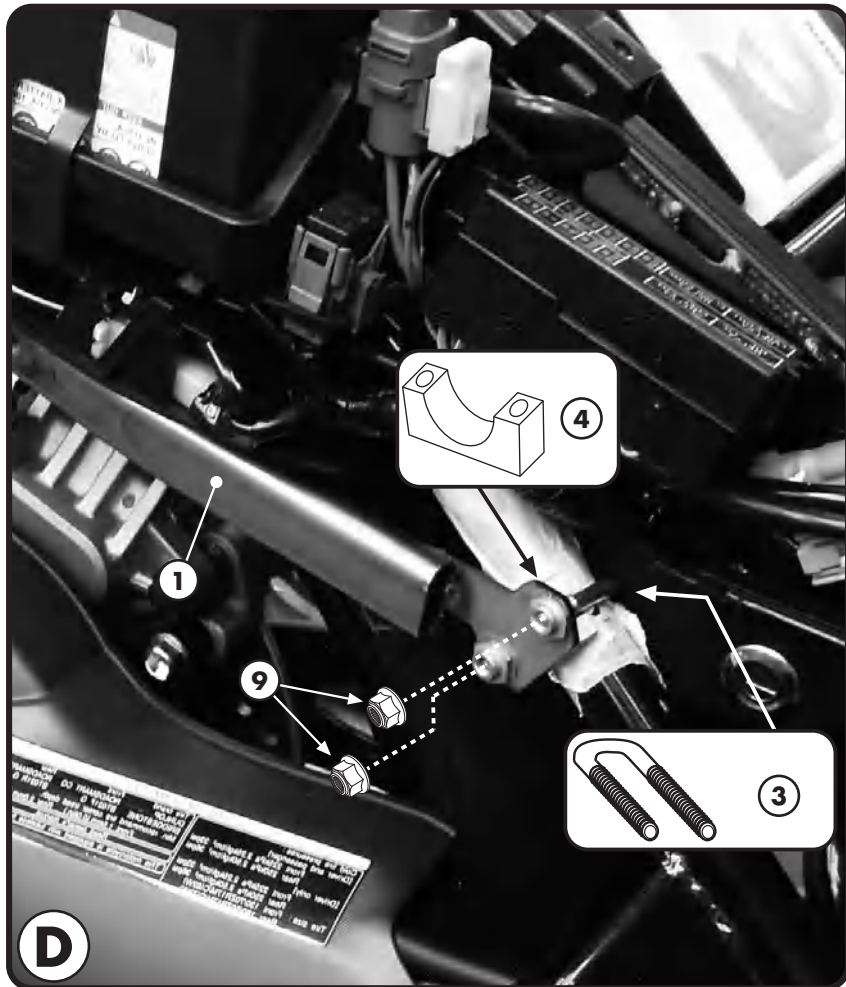
16

COPRIVITE Ø8mm
Z801
SCREW CAP
CACHE VIS
STOPSSCHRAUBE
TAPA TORNILLO
Q.TY n.2



MONORACK SPECIFICO - SPECIFIC MONORACK
MONORACK SPECIFIQUE - SPEZIFISCHES MONORACK - MONORACK ESPECÍFICO

HONDA DN-01 2008

ISTRUZIONI DI MONTAGGIO - MOUNTING INSTRUCTIONS
INSTRUCTIONS DE MONTAGE - BAUANLEITUNG - INSTRUCCIONES DE MONTAJE

I ISTRUZIONI DI MONTAGGIO

1. SMONTARE LE PARTI DI CARENATURA ORIGINALI FINO A RENDERE ACCESIBILI LE PARTI DI PLASTICA RAFFIGURATE IN FOTOGRAFIA A;
2. RITAGLIARE LE DIME DI FORATURA DI PAGINA 1 E UTILIZZARLE PER SEGNARE E SUCCESSIVAMENTE FORARE LE PLASTICHE ORIGINALI COME INDICATO IN FOTOGRAFIA A;
3. MONTARE IL SUPPORTO N°2, FOTOGRAFIA B; FARE ATTENZIONE AD INFILARE IL SUPPORTO NELLA SPACCATURA CHE AVETE APPENA CREATO NELLA PLASTICA ORIGINALE;
4. MONTARE IL SUPPORTO N°1 COME INDICATO IN FOTOGRAFIA C;
5. FISSARE LA PARTE ANTERIORE DEL SUPPORTO N°1 AL TELAIO DELLA MOTOCICLETTA COME INDICATO IN FOTOGRAFIA D;
6. MONTARE LA PIASTRA PORTABAULETTO (NON INCLUSA) COME INDICATO IN FOTOGRAFIA E;
7. ULTIMARE IL MONTAGGIO VERIFICANDO CHE TUTTE LE VITI SIANO SERRATE BENE (VITI M6=9,6Nm - VITI M8=23Nm) E CHE IL TAPPO ANTIFURTO ED I GOMMINI (NON INCLUSI) SIANO MONTATI CORRETTAMENTE SULLA PIASTRA (NON INCLUSA).

GB MOUNTING INSTRUCTIONS

1. REMOVE THE REAR BODY WORK FROM THE BIKE. CUT OUT THE TEMPLATES RIGHT AND LEFT SIDE FROM PAGE 1.
2. PLACE THE TEMPLATES ONTO THE LOWER REAR FENDER AS SHOWN IN PICTURE A TO LINE UP THE BOLT HOLES (MAKE SURE TO USE THE CORRECT SIDE TEMPLATE), THEN SCORE THE LONGER HOLE INTO THE LOWER REAR FENDER, ALSO AS SHOWN IN PICTURE A, AND CUT THROUGH THE THE SCORE MARKS TO CREATE A HOLE, AS SHOWN IN PICTURE B. REPEAT ON OTHER SIDE.
3. PLACE SUPPORT BRACKET #2 THROUGH THE LONG HOLE (MAKE SURE TO USE CORRECT RIGHT OR LEFT SIDE BRACKETS. SCREW SUPPORT BRACKET #2 INTO THE SUBFRAME AS SHOWN IN PICTURE B USING BOLT #6 AND ORIGINAL WASHER #15
4. ATTACH THE MONORACK SIDE ARM (SUPPORTS #1 RIGHT AND LEFT) TO THE LOWER BOLT HOLE OF SUPPORT #2 USING BOLT #8 AND NUT #10, AS SHOWN IN PICTURE C.
5. USING U-CLAMP #3 ATTACH THE FRONT OF THE MONORACK SIDE ARM TO FRAME OF THE BIKE NEAR THE FOOT PEG, AS SHOWN IN PICTURE D.
6. ATTACH THE TOP PLATE TO THE REAR OF THE MONORACK SIDE ARMS, SET THE SCREWS, NUTS, WASHERS, BOLTS ETC. AS SHOWN IN DIAGRAM E.
7. CHECK ALL BOLTS, NUTS, AND WASHERS ARE SECURELY TIGHTENED. REPLACE ALL THE BODY WORK YOU REMOVE IN ITEM 1. ATTACH YOUR GIVI TOP CASE AND ENJOY YOUR RIDE.

F INSTRUCTIONS DE MONTAGE

1. DEMONTER LES PIÈCES DE LA CARROSSERIE AFIN DE RENDRE ACCESSIBLES LES PIÈCES EN PLASTIQUE DE LA PHOTO A;
2. DECOUPER LES EMPREINTES DE PERCAGE, PAGE 1 ET LES UTILISER POUR MARQUER ET PERCER LES PLASTIQUES D'ORIGINE COMME INDIQUE EN PHOTO A;
3. MONTER LES SUPPORTS N°2, PHOTO B; FAIRE TRES ATTENTION A GLISSER LES SUPPORTS EXACTEMENT DANS LES TROUS DEJA REALISES EN PHASE 2;
4. MONTER LES SUPPORTS N°1 COMME INDIQUE EN PHOTO C;
5. FIXER LA PARTIE ANTERIEURE DES SUPPORTS N°1 AU CHASSIS DE LA MOTO COMME INDIQUE EN PHOTO D;
6. MONTER LA PLATINE PORTE-VALISE (NON INCLUSE) COMME INDIQUE EN PHOTO E;
7. TERMINER LE MONTAGE EN CONTROLANT LE BON SERRAGE DE TOUTES LES VIS (VIS M6=9,6Nm - VIS M8=23Nm) ET VEILLER A CE QUE LE BOUCHON ANTIVOL ET LES CAOUTCHOUC SOIENT CORRECTEMENT MONTES SUR LA PLATINE (NON INCLUSE).

D BAUANLEITUNG

1. ENTFERNEN SIE DIE ORIGINALVERKLEIDUNG BIS SIE DIE PLASTIKTEILE, WIE IM BILD A GEZEIGT, ERREICHEN;
2. SCHNEIDEN SIE DIE SCHABLOHNE VON SEITE 1 AUS UND BENUTZEN SIE DIESE UM DIE ORIGINALPLASTIKTEILE ZU MARKIEREN UND BOHREN SIE WIE IM BILD A HINGEWIESEN WIRD;
3. MONTIEREN SIE DIE HALTERUNG NR. 2, BILD B; BITTE BEACHTEN SIE DIESE HALTERUNG DURCH DIE SPALTUNG ZU FÜHREN, DIE SIE IN DEM ORIGINALPLASTIKTEIL GEMACHT HABEN;
4. MONTIEREN SIE DIE HALTERUNG NR. 1 WIE IM BILD C GEZEIGT;
5. BEFESTIGEN SIE DIE VORDERSEITE DER HALTERUNG NR. 1 AN DEM RAHMEN DES MOTORRADS WIE IM BILD D GEZEIGT;
6. MONTIEREN SIE DIE PLATTE DES KOFFERS (NICHT ENTHALTEN) WIE IM BILD E GEZEIGT;
7. ZULETZT ÜBERPRÜFEN SIE DASS ALLE SCHRAUBEN FESTGEZOGEN WURDEN (SCHRAUBEN M6=9,6NM - SCHRAUBEN M8=23NM) SOWIE DASS DIE DIEBSTAHLSTÖPSEL UND DIE GUMMISTÖPSEL (NICHT ENTHALTEN) AUF DER PLATTE (NICHT ENTHALTEN) KORREKT MONTIERT WURDEN.

ES

INSTRUCCIONES DE MONTAJE

1. DESARMAR LAS PARTES DE CARENADO ORIGINALES HASTA QUE LAS PARTES DE PLÁSTICO REPRESENTADAS EN LA FOTOGRAFÍA A ESTÉN ACCESIBLES;
2. RECORTAR LAS CUÑAS DE PERFORACIÓN DE LA PÁGINA 1 Y UTILIZARLAS PARA MARCAR Y LUEGO PERFORAR LOS PLÁSTICOS ORIGINALES SEGÚN LO INDICADO EN LA FOTOGRAFÍA A;
3. MONTAR EL SOPORTE N° 2, FOTOGRAFÍA B; PONER ATENCIÓN AL INSERTAR EL SOPORTE EN LA APERTURA QUE ACABÁIS DE CREAR EN EL PLÁSTICO ORIGINAL;
4. MONTAR EL SOPORTE N° 1 CONFORME A LO INDICADO EN LA FOTOGRAFÍA C;
5. ANCLAR LA PARTE DELANTERA DEL SOPORTE N° 1 AL CHASIS DE LA MOTOCICLETA CONFORME A LO INDICADO EN LA FOTOGRAFÍA D;
6. MONTAR LA PLANCHA PIRTA-MALETIN (NO INCLUIDA) SEGÚN LO INDICADO EN LA FOTOGRAFÍA E;
7. COMPLETAR EL ARMADO VERIFICANDO QUE TODOS LOS TORNILLOS ESTÉN PERFECTAMENTE AJUSTADOS (TORNILLOS M6=9,6Nm - TORNILLOS M8=23Nm) Y QUE LA TAPA ANTIRROBO Y LOS ANILLOS DE GOMA (NO INCLUIDOS) ESTÉN MONTADOS CORRECTAMENTE EN LA PLANCHA (NO INCLUIDA).