

SR310 - KR310

PORTAVALIGIA SPECIFICO - SPECIFIC CASE HOLDER
 PORTE-VALISE SP CIFIQUE - SPEZIFISCHER KOFFER-TR GER
 PORTA-EQUIPAJE ESPECIFICO

DUCATI MULTISTRADA '03/'05

1000cc

ISTRUZIONI DI MONTAGGIO - MOUNTING INSTRUCTIONS
 INSTRUCTIONS DE MONTAGE - BAUANLEITUNG - INSTRUCCIONES DE MONTAJE



1
SUPPORTO
 SUPPORT
 SUPPORT
 HALTERUNG
 SOPORTE

Q.TY n.1

2

PIASTRA MONOKEY
Z622M
 PLATE
 PLATINE
 PLATTE
 PARRILLA

Q.TY n.1

3

VITE TCEI M6x35mm
 SCREW M6x35mm
 VIS M6x35mm
 SCHRAUBE M6x35mm
 TORNILLO M6x35mm

Q.TY n.4

4

RONDELLA f16mm
 WASHER Ø6mm
 RONDELLE Ø6mm
 SCHEIBE Ø6mm
 ARANDELA Ø6mm

Q.TY n.4

5

DADO A.B. M6
 BOLT M6
 ECROU M6
 MUTTER M6
 TUERCA M6

Q.TY n.4

6

COPRIFORO
Z621
 BOLT CAP
 CACHE TROU
 STOPLOCK
 TAPA AGUJERO

Q.TY n.6

7

RONDELLA f16x18mm
 WASHER Ø6x18mm
 RONDELLE Ø6x18mm
 SCHEIBE Ø6x18mm
 ARANDELA Ø6x18mm

Q.TY n.4

8

VITE TSCEI M6x45mm
 SCREW M6x45mm
 VIS M6x45mm
 SCHRAUBE M6x45mm
 TORNILLO M6x45mm

Q.TY n.4

9

VITE TBEI M6x16mm
 SCREW M6x16mm
 VIS M6x16mm
 SCHRAUBE M6x16mm
 TORNILLO M6x16mm

Q.TY n.4

10

GOMMINO
Z1822
 RUBBER
 CAOUTCHOUC
 GUMMI
 GOMA

Q.TY n.4

11

DISTANZIALE f11x11mm
foro f16,5mm
V687
 SPACER
 ENTRETOISE
 DISTANZSTUECK
 DISTANCIADOR

Q.TY n. 4

ATTENZIONE: PESO MASSIMO SOPPORTABILE 10Kg.

WARNING: MAX. LOADING OF THE CARRIER 10Kg.(21lbs)

ATTENTION: CHARGE MAXIMALE 10Kg.

ACHTUNG: MAXIMALE BELASTUNG 10Kg.

¡ATENCIÓN! CARGA MÁXIMA AUTORIZADA 10Kg.

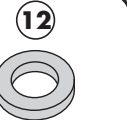
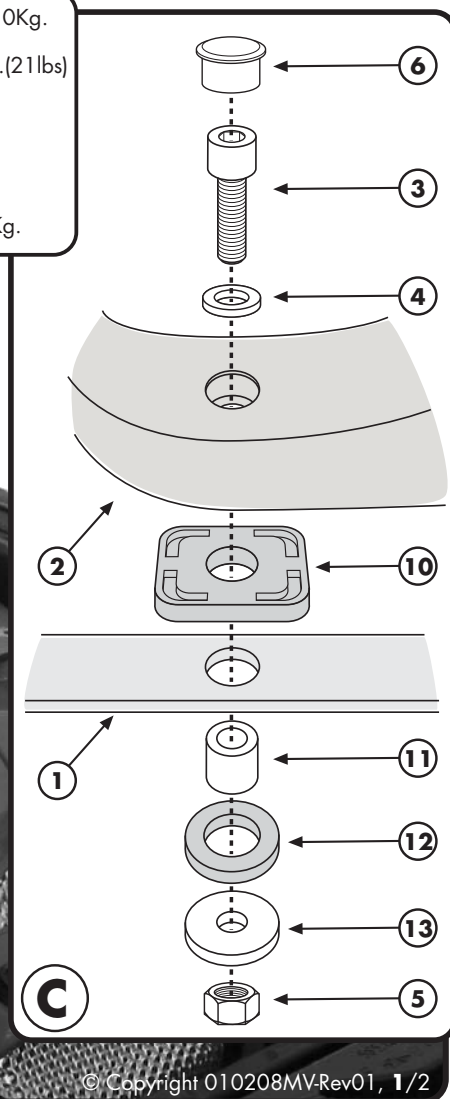
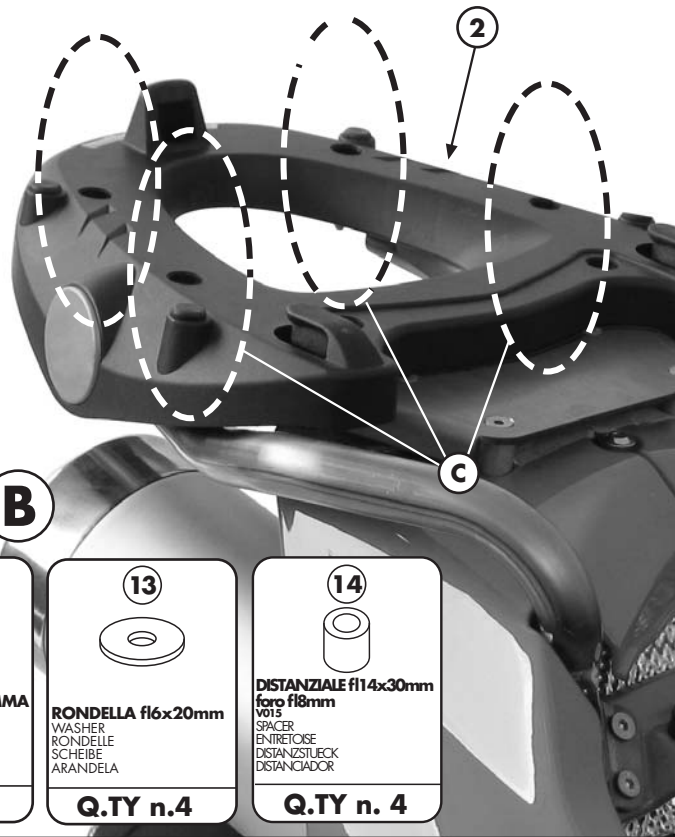
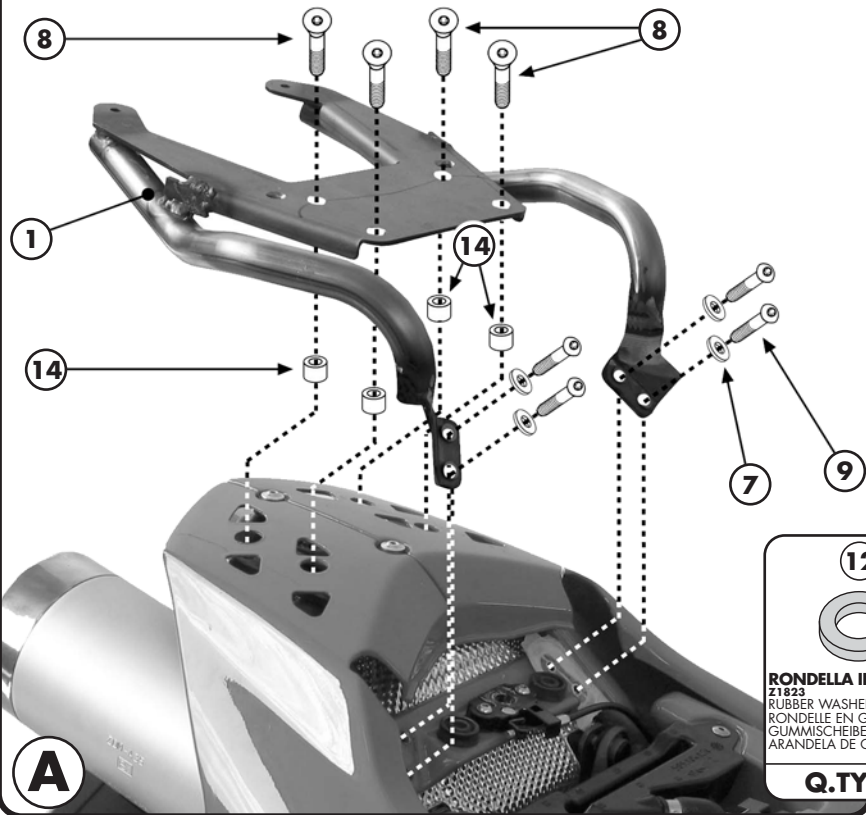

12
RONDELLA IN GOMMA
Z1823
 RUBBER WASHER
 RONDELLE EN GOMME
 GUMMISCHEIBE
 ARANDELA DE GOMA

Q.TY n.4

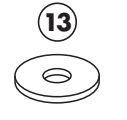

13
RONDELLA f16x20mm
 WASHER
 RONDELLE
 SCHEIBE
 ARANDELA

Q.TY n.4



14
DISTANZIALE f114x30mm
foro f18mm
V015
 SPACER
 ENTRETOISE
 DISTANZSTUECK
 DISTANCIADOR

Q.TY n. 4

PORTAVALIGIA SPECIFICO - SPECIFIC CASE HOLDER
 PORTE-VALISE SP CIFIQUE - SPEZIFISCHER KOFFER-TR GER
 PORTA-EQUIPAJE ESPECCEFICO

DUCATI MULTISTRADA '03/'05

1000cc

ISTRUZIONI DI MONTAGGIO - MOUNTING INSTRUCTIONS
 INSTRUCTIONS DE MONTAGE - BAUANLEITUNG - INSTRUCCIONES DE MONTAJE

I ISTRUZIONI DI MONTAGGIO

1. SMONTARE IL MANIGLIONE ORIGINALE DALLA CODA DELLA MOTOCICLETTA;
2. TOGLIERE LE GUARNIZIONI IN GOMMA ORIGINALI;
3. POSIZIONARE IL SUPPORTO N°1 COME MOSTRATO IN FOTO A;
4. CONTROLLARE CHE LE VITI SIANO SERRATE BENE;
5. MONTARE LA PIASTRA, PARTICOLARE N°2, COME INDICATO IN FOTO B;
6. ULTIMARE IL MONTAGGIO CONTROLLANDO CHE TUTTE LE VITI SIANO SERRATE BENE.

GB MOUNTING INSTRUCTIONS

1. REMOVE THE ORIGINAL HANDLEBAR OF THE REAR FAIRING;
2. REMOVE THE ORIGINAL RUBBER WASHERS;
3. PLACE THE SUPPORT N° 1 AS SHOWN IN PICTURE A;
4. CHECK THAT THE SCREWS HAVE BEEN TIGHTENED;
5. MOUNT THE PLATE, PART N° 2, AS SHOWN IN PICTURE B;
6. LASTLY CHECK THAT ALL SCREWS ARE TIGHT.

F INSTRUCTIONS DE MONTAGE

1. DEMONTER LES POIGNEES PASSGER D'ORIGINE DE SUR LA MOTO;
2. ENLEVER LES PROTECTIONS CAOUTCHOUC D'ORIGINE;
3. POSITIONNER LE SUPPORT N°1 COMME MONTRE SUR LA PHOTO A;
4. CONTROLER LE BON SERRAGE DES VIS;
5. MONTER LA PLATINE, PIECE N°2, COMME INDIQUE SUR LA PHOTO B;
6. TERMINER LE MONTAGE EN CONTROLANT LE BON SERRAGE DE TOUTES LES VIS.

D BAUANLEITUNG

1. NEHMEN SIE DEN ORIGINAL HANDGRIFF DES FAHRZEUGSHECKS AB;
2. ENTFERNEN SIE DIE ORIGINAL GUMMIDICHTUNGEN;
3. POSITIONIEREN SIE DIE HALTERUNG NR. 1 WIE IM BILD A BESCHRIEBEN;
4. UBERPRUFEN SIE, DASS ALLE SCHRAUBEN FESTGEZOGEN WURDEN;
5. MONTIEREN SIE DIE PLATTE, TEIL NR. 2, WIE IM BILD B BESCHRIEBEN;
6. ZULETZT ZIEHEN SIE ALLE SCHRAUBEN FEST.

ES

INSTRUCCIONES DE MONTAJE

1. DESMONTAR EL ASA ORIGINAL DEL COLÍN DE LA MOTO,
2. QUITAR LA JUNTAS ORIGINALES EN GOMA;
3. MONTAR EL SOPORTE N° 1 COMO ENSEÑA LA FOTO A;
4. CONTROLAR QUE TODOS LOS TORNILLOS ESTÉN BIEN APRETADO;
5. MONTAR LA PARRILLA N° 2 COMO INDICA LA FOTO B;
6. TERMINAR APRETANDO TODOS LOS TORNILLOS