

EA123

BORSA DA SERBATOIO TANKLOCK - TANKLOCK BAG - SACOCHE DE RÉSERVOIR TANKLOCK
TANKRUCKSACK TANKLOCK - BOLSA DE SOBREDEPÓSITO TANKLOCK



ATTENZIONE: Verificare il corretto aggancio delle borse prima di mettersi in marcia.

WARNING: Fasten the bags before march off.

ATTENTION: Vérifier la bonne accroche des sacoches avant la mise en route.

ACHTUNG: Prüfen Sie bitte die Befestigung der Taschen bevor Sie fahren

ATENCIÓN: Comprobar si esta correcto el anclaje de las bolsas antes de ponerse en marcha.

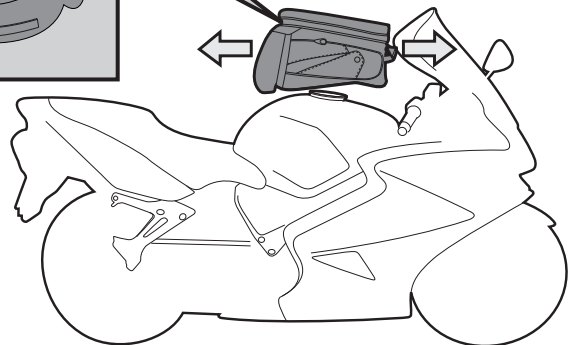
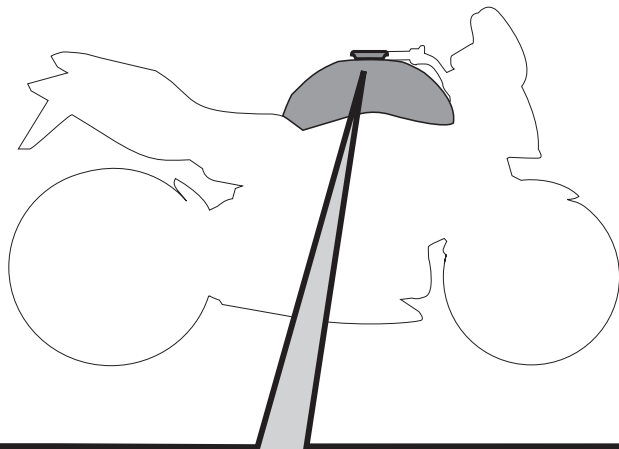
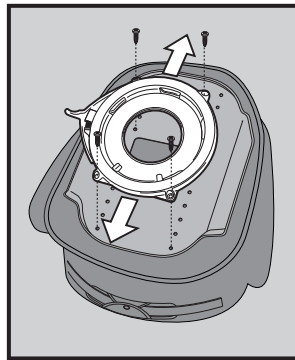

LOCK

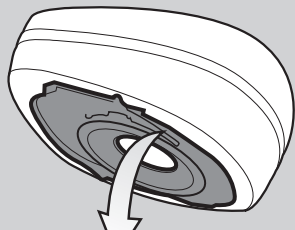

PUSH > CLACK! > LOCKED

RELEASE

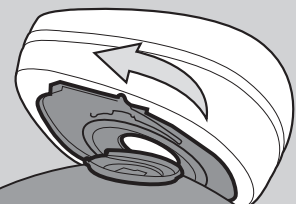

EA123

BORSA DA SERBATOIO TANKLOCK - TANKLOCK BAG - SACOCHE DE RÉSERVOIR TANKLOCK
TANKRUCKSACK TANKLOCK - BOLSA DE SOBREDEPÓSITO TANKLOCK

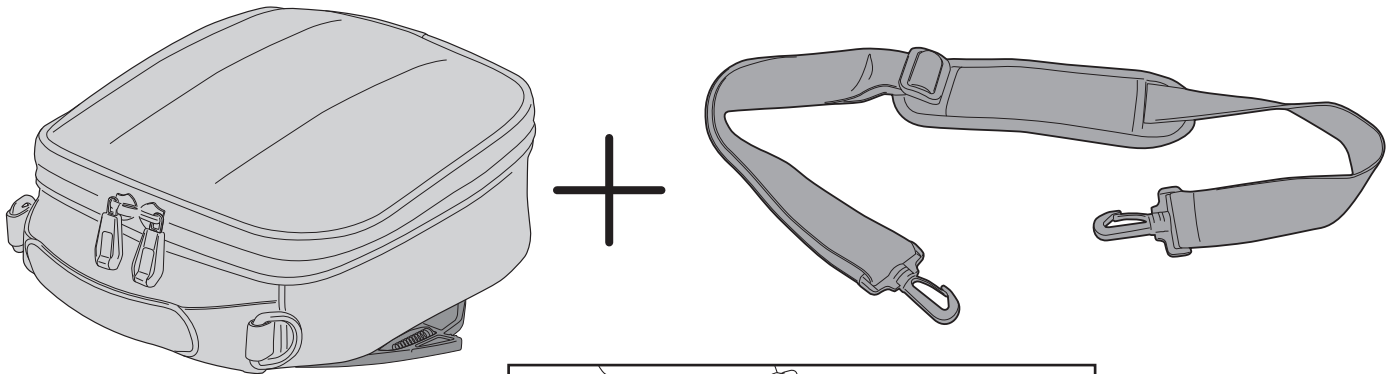

- VERIFICARE ATTENTAMENTE CHE LA BORSA NON PREGIUDICHI L'ORIGINARIA GUIDABILITÀ DEL MEZZO, FACENDO PARTICOLARE ATTENZIONE AD EVENTUALI INTERFERENZE CON IL MANUBRIO.
- PLEASE CHECK CAREFULLY THAT THE BAG WILL NOT EFFECT THE ORIGINAL DRIVEABILITY, PAYING PARTICULAR ATTENTION TO ANY POSSIBLE INTERFERENCE WITH THE HANDLEBARS.
- BITTE PRÜFEN SIE DASS DIESES MODELL DIE ORIGINALFAHRT DES FAHRZEUGES NICHT BEEINTRÄCHTIGT. WIR BITTEN SIE AUF EVENTUELLE STÖRUNGEN AN DEM LENKER BESONDERS ZU ACHTEN.
- VEUILLEZ VÉRIFIER SOIGNEUSEMENT QUE LA SACOCHE N'AFECTERA PAS LA MANIABILITÉ DU VÉHICULE, EN ACCORDANT UNE ATTENTION PARTICULIÈRE À TOUTE INTERFÉRENCE POSSIBLE AVEC LE GUIDON.
- VERIFICAR ATENTAMENTE QUE LA BOLSA NO PERJUDIQUE LA ORIGINAL CONDUCCIÓN DEL VEHÍCULO, PRESTANDO ESPECIAL ATENCIÓN A UNA EVENTUAL INTERFERENCIA CON EL MANILLAR.
- VERIFICAR CUIDADOSAMENTE QUE A BOLSA NÃO PREJUDIQUE A CONDUÇÃO ORIGINAL DO VEICULO, COM ATENÇÃO ESPECIAL EM INTERFERÊNCIAS EVENTUAL NO GUIDÃO DA MOTOCICLETA.